

THIS DRAWING IS UNPUBLISHED. RELEASED FOR PUBLICATION, 19
 © COPYRIGHT 19 BY AMP INCORPORATED. ALL INTERNATIONAL RIGHTS RESERVED.

LOC	DIST	P	F	ZONE	LTR	REVISIONS	DATE	APPD
AF	50				V	REDRAWN PER 0710-0005-95	07/APR/95	PF/GY

1 CONTINUOUS STRIP ON REEL.

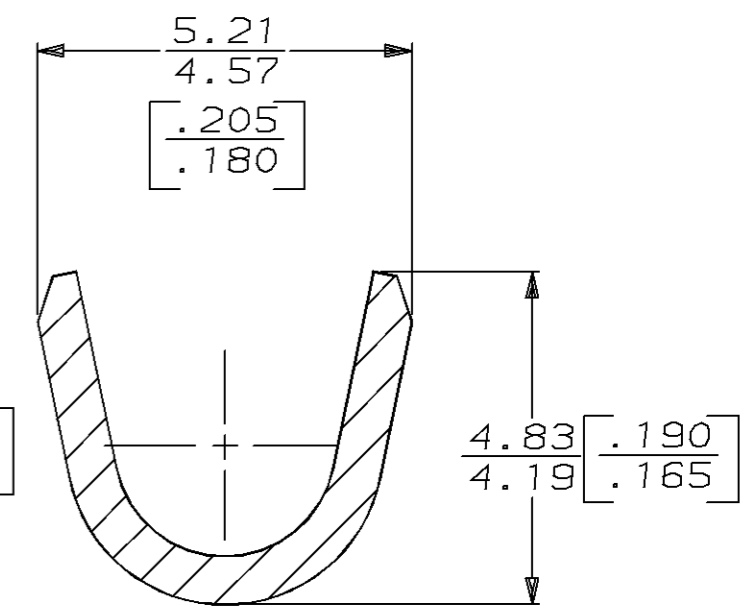
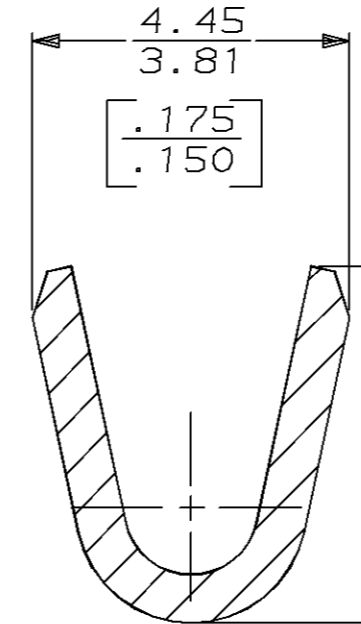
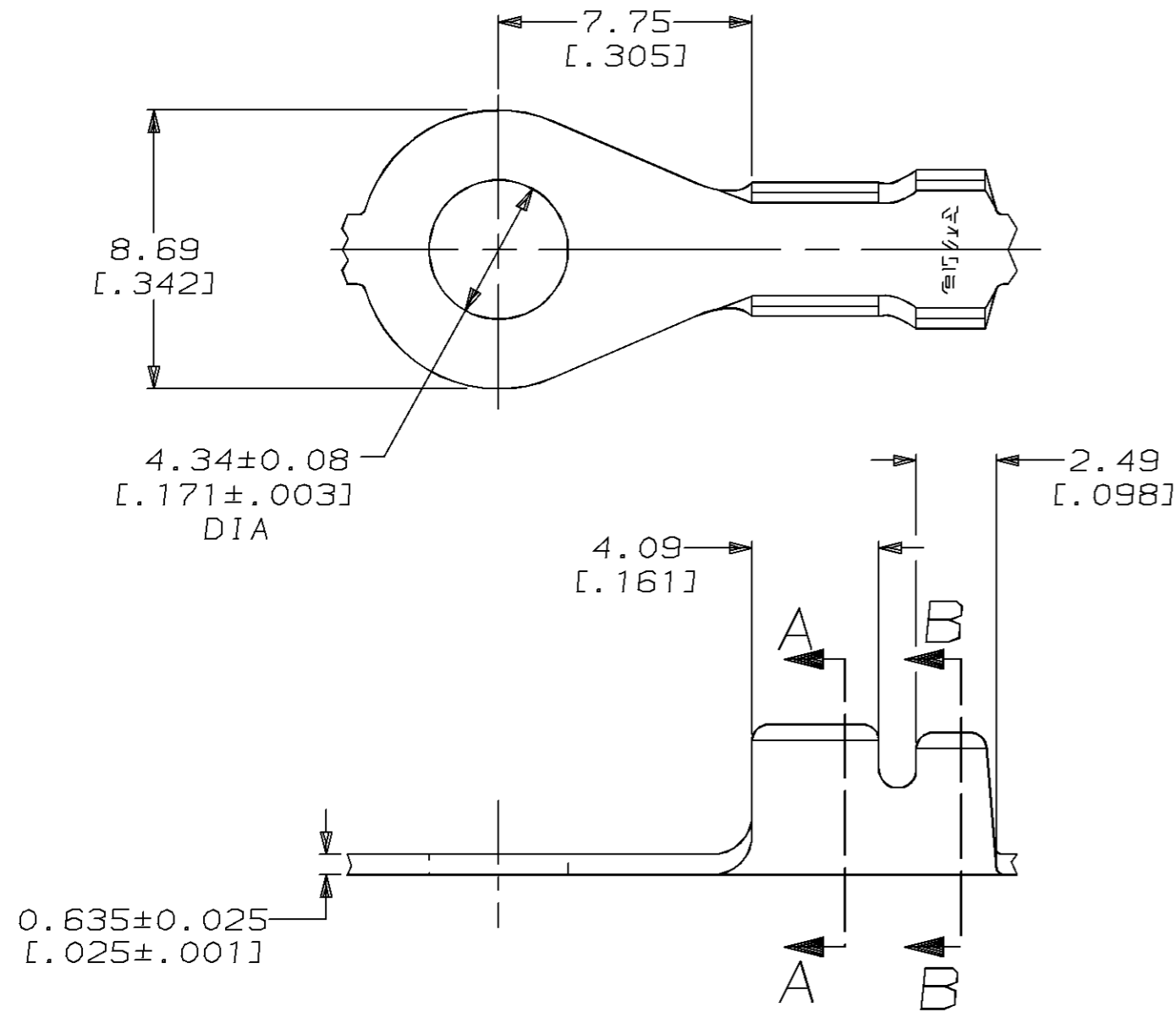

THIS DRAWING IS A CONTROLLED DOCUMENT FOR AMP INCORPORATED. IT IS SUBJECT TO CHANGE AND THE CONTROLLING ENGINEERING ORGANIZATION SHOULD BE CONTACTED FOR THE LATEST REVISION.

2.54-3.56 DIA [.100-.140]		[18-14] AWG	60024-2
INSULATION RANGE		WIRE RANGE	PART NO
DO NOT SCALE PRINT. UNLESS SPECIFIED DIMENSIONS IN mm [INCHES] TOLERANCES ON: 2 PLC DEC ± 0.25 [.010] 3 PLC DEC ± - ANGLES ± -	DR 07/APR/95 PHILLIP M FORTNEY	AMP AMP Incorporated Harrisburg, PA 17105-3608 NAME RING SIZE [B] CAGE CODE 00779 DRAWING NO C-60024 SCALE 5:1 SHEET 1 OF 1	
	CHK 07/APR/95 JEFF R RUTH		
	APPD 07/APR/95 GARY YETTER		
	APPD 07/APR/95 MARK BARNABA		
MATERIAL 082 BRASS	PRODUCT SPEC -		
FINISH 0.002032 [.000080] MIN TIN PLATE PER MIL-T-10727	APPLICATION SPEC -		
WEIGHT -			